

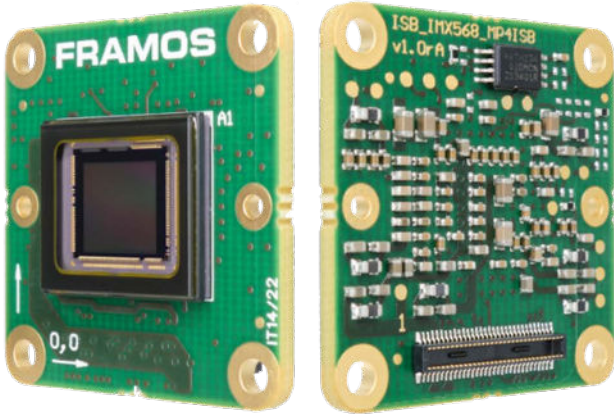

FSM-IMX568 Datasheet

Sony IMX568AAMJ-M / IMX568AAQJ-C Sensor Module

FRAMOS Sensor Module



Key Benefits & Features:

- 5.1 Mpx Sony CMOS Global Shutter sensor module, ready to embed!
- All FSMs are part of a rapid prototyping ecosystem, consisting of:
 - ✓ Adapters to various processing boards
 - ✓ Design sources for deep embedding
 - ✓ Various accessories and design in services

FSM-IMX568M (Monochrome):

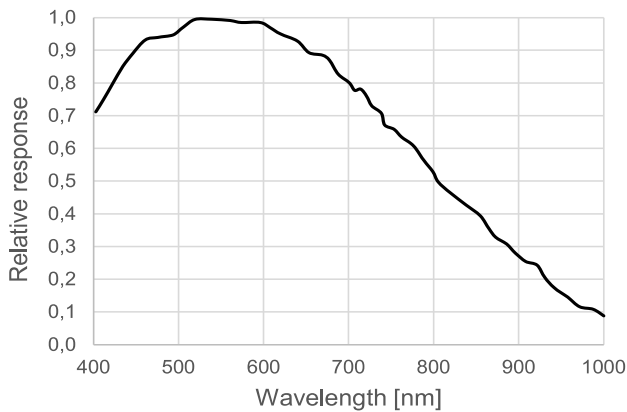

FSM-IMX568C (Color):

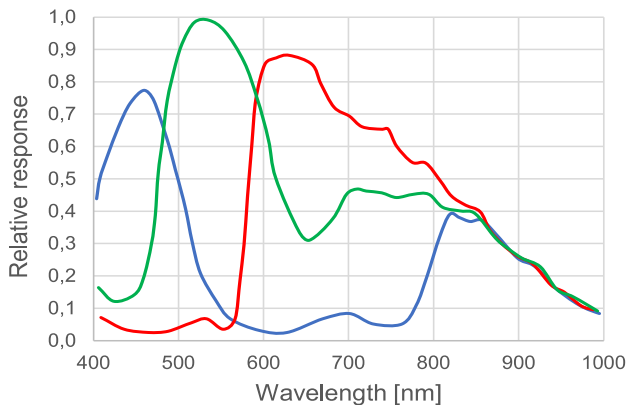

For further information on operating a sensor module of the FSM Ecosystem, reference the FSM Ecosystem User Manual.

Specification	
Model Name	FSM-IMX568M / FSM-IMX568C (V1A)
Image Sensor	
Vendor / Name	Sony IMX568AAMJ-M / IMX568AAQJ-C
Shutter Type	CMOS Global Shutter
Technology / Grade	Pregius S (Gen4) / Industrial
Chromaticity	Color / Mono
Optical Format	1/1.8"
Pixel Size	2.74 x 2.74 μm
Max. Resolution	5.1 Mpx / 2472 x 2064 px
Framerate (max.)	96.2 FPS (4-Lane) 51.7 FPS (2-Lane)
Bit Depth(s)	8 / 10 / 12 bit
Interface	
Data Interface	MIPI CSI-2 (2 / 4 Lane)
Communication Interface	I ² C
Drive Frequency(s)	37.125 / 54 / 74.25 MHz
Input Voltages	1.1V, 1.8V, 3.3V
Interface Connector	Hirose DF40C-60DP-0.4V(51)
EEPROM (Sensor ID)	Yes
Mechanical	
Dimensions (HxW)	26.5 x 26.5
Environmental	
Operating Temperature	-30°C to +85°C (function) -10°C to +60°C (performance)
Storage Temperature	-40°C to +85°C
Ambient Humidity	20% to 95% RH, non condensing
Software Support	
Driver	V4L2 Based Device Driver Libargus / Argus Camera (ISP Tuned) Isaac ROS compliant
Supported Platform(s)	NVIDIA Jetson Family: AGX Xavier, Nano, TX2 (NX), Xavier NX, AGX Orin
Software Version(s)	NVIDIA JP4.6.1 / L4T32.7.1
Suggested Accessories & Adapters	
Compatible FSA Type	FSA-FT26/A
Recommended Devkit(s)	FSM-IMX568C/TXA_Devkit (TX2, AGX) FSM-IMX568C/NVN_Devkit (Nano, NX)
Lens Mounts	M12 or C/CS-Mount options
A matrix with compatible <i>Sensor Adapters (FSA)</i> and <i>Processor Board Adapters (FPA)</i> for various setups can be found at the end of this document.	

Mechanical Drawing

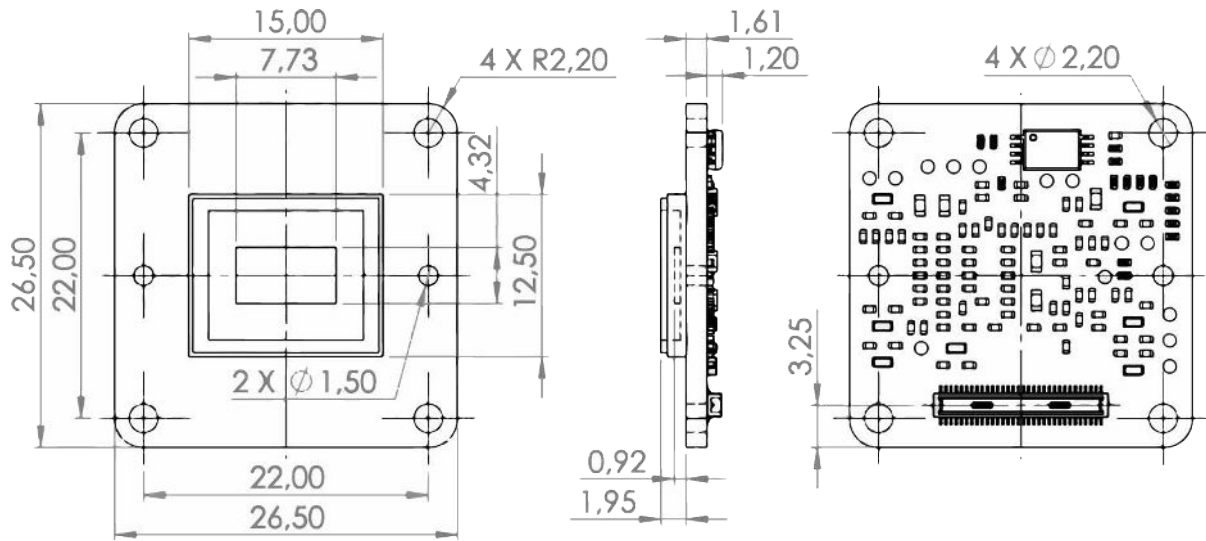

Sensor image optical center is in mechanical board center.

Connector Pinout

Type: Hirose DF40C-60DP-0.4V(51)

Mating Type: Hirose DF40HC(4.0)-60DS-0.4V(51)

Pin	Name
1	NC
3	NC
5	3V3_A
7	3V3_A
9	1V8_IO
11	GND
13	GND
15	XCLR
17	NC
19	XMASTER
21	SCL
23	XCE
25	XVS
27	SDA
29	XHS
31	XTRIG1
33	NC
35	SLAMODE0
37	GND
39	INCK
41	NC
43	GND
45	NC
47	NC
49	GND
51	D_DATA_0_N
53	D_DATA_0_P
55	GND
57	D_DATA_2_P
59	D_DATA_2_N

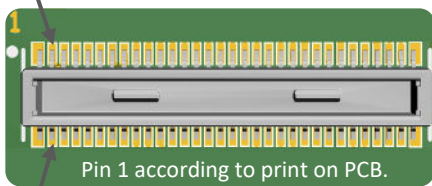

Pin	Name
2	1V8
4	1V8
6	1V1_D
8	1V1_D
10	2V9_A
12	GND
14	GND
16	NC
18	SDO
20	NC
22	NC
24	SLAMODE2_R
26	NC
28	NC
30	NC
32	TOUT0
34	NC
36	SLAMODE1
38	GND
40	NC
42	NC
44	GND
46	D_DATA_3_P
48	D_DATA_3_N
50	GND
52	D_DATA_1_N
54	D_DATA_1_P
56	GND
58	D_CLK_0_P
60	D_CLK_0_N

Signals are routed directly from image sensor to connector. Details on specific signals are described in the respective image sensor datasheet.