

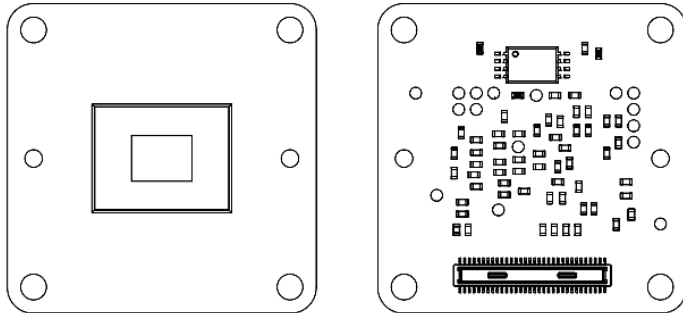

FRAMOS Sensor Module  
2023-04-13  
Version v1.0a

# FRAMOS Datasheet



## Contact Information

FRAMOS GmbH

Technical Support:  
[support@framos.com](mailto:support@framos.com)  
Website:  
<https://www.framos.com>

## FSM-IMX675

a Sony® IMX675AAQR Sensor Module

### General Description:

This FRAMOS Sensor Module (FSM) provides the Sony IMX675 sensor on a very compact module. The Rolling Shutter sensor has a native resolution of 5 [MP] and an optical format of 1/2.8 inch at a pixel size of 2 x 2  $\mu\text{m}$ . The Module has a MIPI CSI-2 interface with up to 4-data lanes.

FRAMOS Sensor Modules enable users to seamlessly plug the latest image sensor technology into common processing platforms. These modules feature a fully modular design that utilizes standardized connectors and mechanicals. The modules include image sensors on a PCB and have resolutions from 0.4 MP to 24 MP with both rolling and global shutter options. FRAMOS Sensor Modules are ideal in evaluating a sensor as part of a proof-of-concept design. The modules also can compare and contrast multiple sensors using a common backend and integrate them into third-party processor boards.

### Targeted Use:

Applications for industry, security and surveillance, and consumer cameras.

## Specifications:

Model Name	FSM-IMX675C (V1A)
------------	-------------------

### Image Sensor

Vendor	Sony IMX675AAQR
Shutter Type	CMOS Rolling Shutter
Technology / Grade	Starvis2 / Security
Chromacity	Color
Optical Format	1/2.8"
Pixel Size	2 x 2 $\mu\text{m}$
Maximum Resolution	5 Mpx / 2592 x 1944 px
Framerate (Maximum)	80 FPS (4-Lane) 60 FPS (2-Lane)
Bit Depth	10 / 12 bit

### Interface

Data Interface	MIPI CSI-2 (2 / 4 Lane)
Communication Interface	I <sup>2</sup> C
Drive Frequency	24 / 27 / 37.125 / 72 / 74.25 MHz
Input Voltages	1.1V, 1.8V, 3.3V
Interface Connector	Hirose DF40C-60DP-0.4V(51)
EEPROM (Sensor ID)	Yes

### Mechanical

Dimensions (H x W)	26.5 mm x 26.5 mm
--------------------	-------------------

### Environmental

Operating Temperature	-30°C to +85°C (function) -10°C to +60°C (performance)
Storage Temperature	-40°C to +85°C
Ambient Humidity	20% to 95% RH, non condensing

### Software Support

Driver	V4L2 Based Device Driver Libargus / Argus Camera (ISP Tuned) Isaac ROS compliant
Supported Platforms	NVIDIA Jetson Family: AGX Xavier, Xavier NX, AGX Orin.
Software Version(s)	NVIDIA JP5.1 / L4T35.2.1

### Suggested Accessories and Adapters

Compatible FSA Type	FSA-FT26/A
Recommended Devkit(s)	FSM-IMX675C/TXA_Devkit (AGX) FSM-IMX675C/NVN_Devkit (NX)
Lens Mounts	M12 or C/CS-Mount options

## Features:

- Image sensors on a PCB with connector, available off-the-shelf.
- Large lineup of products with resolutions from 0.4MP to 24MP, available with either rolling or global shutter imagers
- Available with MIPI CSI-2 (D-PHY) output.
- Converter boards for SubLVDS and SLVS imagers
- Standardized mechanicals with small footprints of 26.5 x 26.5 mm and 28 x 28 mm

## Applications:

- Engineers looking to reduce their time-to-market with a rapid prototyping module, ready to integrate to various third party processing platforms.
- Embedded vision projects which benefit from an open platform by diving down to the component level. Gauge implementations against Sony's reference.
- Make educated "build vs buy" decisions and benefit from FRAMOS's long-term camera development experience for your tailored productization.

**Note** Some modules are compatible with earlier versions of Jetpack. Contact us for further available options.

**Note** A matrix with compatible Sensor Adapters (FSA) and Processor Board Adapters (FPA) for various setups can be found in the FSM Ecosystem User Manual.

# PixelMate™ Connector Pinout and Signal Description

**WARNING** Pin 1 is identified on the board. Orient accordingly, paying close attention to the pin number in reference to the locator view illustrated below. Failure to align correctly will cause permanent damage.

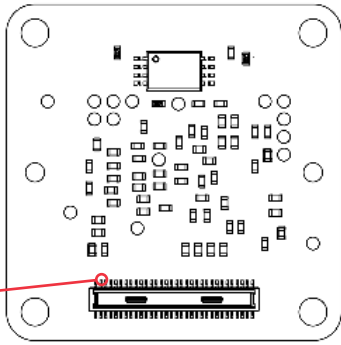

**Note** Signals are routed directly from image sensor to connector. Details on specific signals are described in the respective Sony® image sensor datasheet.

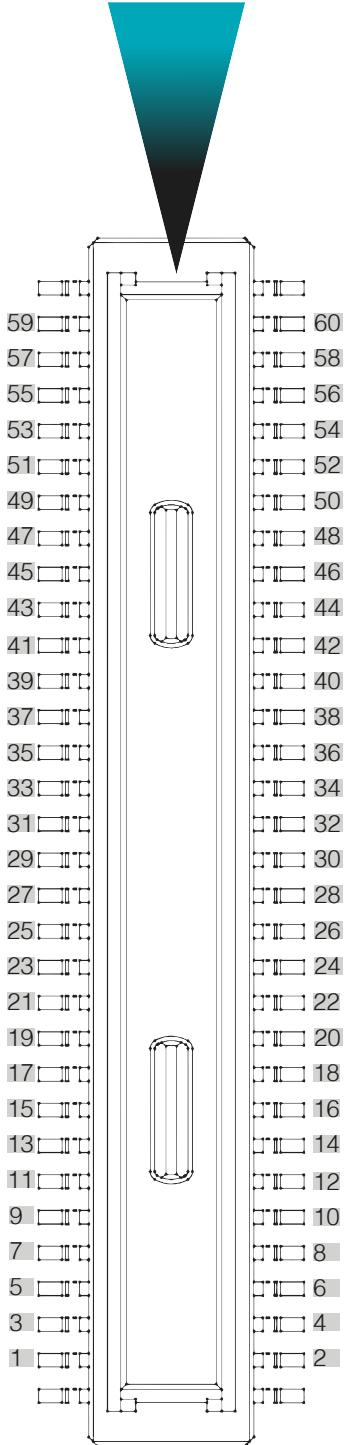

J1 Pin	Pin Description	J1 Pin	Pin Description
Pin1	NC	Pin2	1V8
Pin3	NC	Pin4	1V8
Pin5	3V3	Pin6	1V1
Pin7	3V3	Pin8	1V1
Pin9	1V8	Pin10	NC
Pin11	GND	Pin12	GND
Pin13	GND	Pin14	GND
Pin15	XCLR	Pin16	NC
Pin17	NC	Pin18	NC
Pin19	XMASTER	Pin20	TOUT
Pin21	SCL	Pin22	NC
Pin23	NC	Pin24	NC
Pin25	XVS	Pin26	NC
Pin27	SDA	Pin28	NC
Pin29	XHS	Pin30	TENABLE
Pin31	NC	Pin32	TOUT
Pin33	NC	Pin34	NC
Pin35	SLAMODE0	Pin36	SLAMODE1
Pin37	NC	Pin38	NC
Pin39	INCK	Pin40	NC
Pin41	NC	Pin42	NC
Pin43	GND	Pin44	GND
Pin45	NC	Pin46	D_DATA_3_P
Pin47	NC	Pin48	D_DATA_3_N
Pin49	GND	Pin50	GND
Pin51	D_DATA_0_N	Pin52	D_DATA_1_N
Pin53	D_DATA_0_P	Pin54	D_DATA_1_P
Pin55	GND	Pin56	GND
Pin57	D_DATA_2_P	Pin58	D_CLK_0_P
Pin59	D_DATA_2_N	Pin60	D_CLK_0_N

# Physical Dimensions

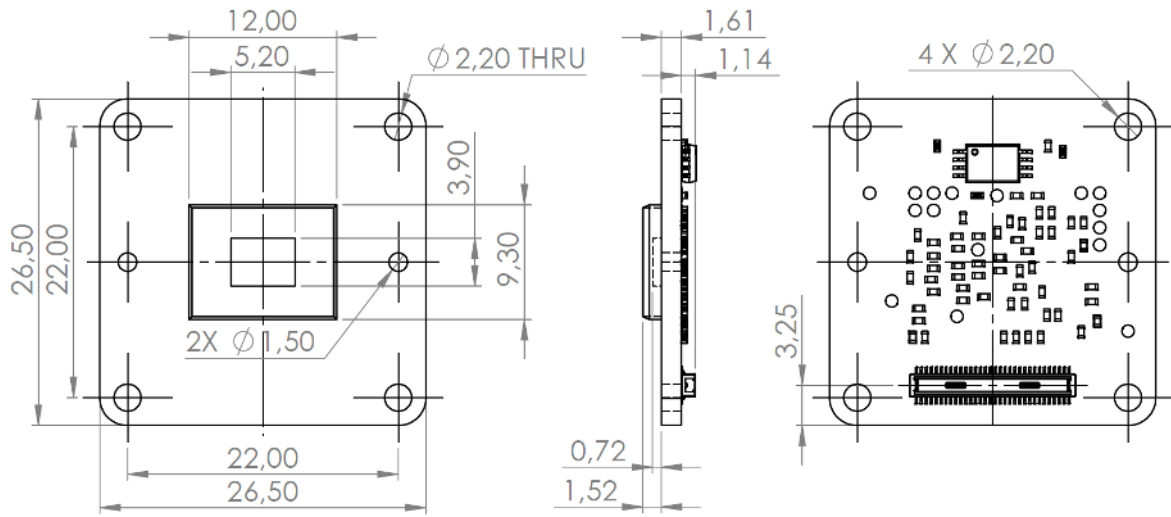

## FSM-IMX675C (Color) Spectral Sensitivity

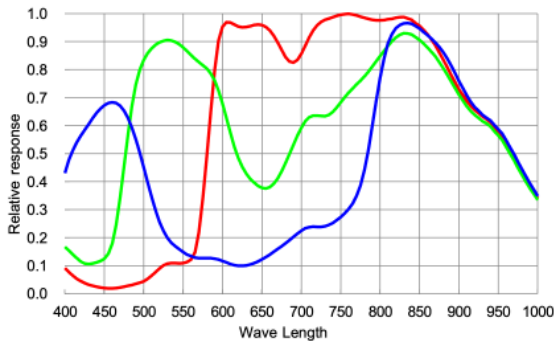

**Note** Additional information surrounding the image sensor can be found in the Sony® datasheets.

## Testpoints

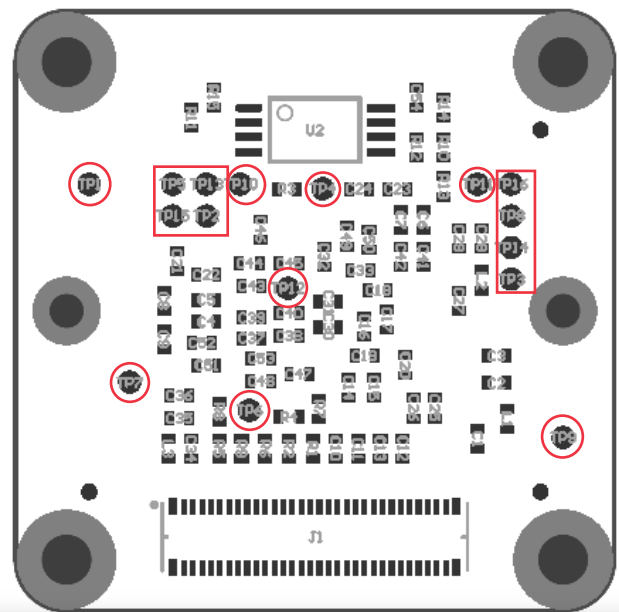

Test Point	Description	Test Point	Description
TP1	GND	TP9	GND
TP2	XVS	TP10	TOUT1
TP3	1V1_D	TP11	INCK
TP4	XHS	TP12	TVMON
TP5	1V8_IO	TP13	XCLR
TP6	TENABLE	TP14	1V1_D2
TP7	3V3_A1	TP15	SCL
TP8	TOUT0	TP16	SDA

## Order Codes

<b>FSM-IMX675C-M01-V1A</b>	No lens mount
<b>FSM-IMX675C-M01-V1A</b>	M12 Mount, 8.6 mm length (FLA-MA-M-08622-00)
<b>FSM-IMX675C-M02-V1A</b>	M12 Mount, 12.5 mm length (FLA-MI-M-12522-00)
<b>FSM-IMX675C-M03-V1A</b>	M12 Mount, 16.2 mm length (FLA-MO-M-16222-00)
<b>FSM-IMX675C-CCS-V1A</b>	CS-Mount with C-Mount Adapter (FMA-MNT-CCS/265-V1A)

While every precaution has been taken in the preparation of this document, the publisher and the author assume no responsibility for errors or omissions, or for damages resulting from the use of information contained in this document or from the use of hardware, programs and source code that may accompany it. In no event shall the publisher and the author be liable for any loss of profit or any other commercial damage caused or alleged to have been caused directly or indirectly by this document.